

also shows a much weaker Mössbauer resonance at room temperature than its toluene analog,<sup>19</sup> as do our compounds where additional substitution on the phenyl ring or incorporation of a biphenylene ring system apparently serves to disrupt the layer structure.<sup>22</sup>

The stronger (p→d)  $\pi$  intermolecular O→Sn bonding in *o*-phenylenedioxytin(II) is shown as well in the lower isomer shift of this compound relative to the others in Table I. Ionic stannous compounds have the electronic configuration Sn[Kr]4d<sup>10</sup>5s<sup>2</sup>, while covalent stannous compounds should have an intermediate s-electron density at tin depending upon the nature of their hybridization and the partial ionic character of their bonds. In a homologous series the amount of d-orbital involvement in the tin hybrid may be seen with reference to the Mössbauer isomer shift which measures s-electron density at the tin nucleus: the greater the d-orbital character the less the s character of the hybrid and the lower the Mössbauer isomer shift. The higher isomer shifts of the other

five- and seven-membered heterocycles correlate with greater solubility, lower thermal stability, greater ease of hydrolysis, and lower temperatures of sublimation.<sup>9-12</sup>

Hydrolysis of the tin(II) heterocycles on standing either in air (where differential thermal analysis shows about 10% hydrolysis per month) or in alcoholic potassium hydroxide<sup>9</sup> regenerates the dihydric organic phenol starting material. The black refractory material frequently found in sublimation residues was assumed to be stannous oxide. Figure 1 shows the Mössbauer spectrum of a sample of 3,4-toluenedioxytin(II) allowed to hydrolyze over a long period in air. The resonance at zero isomer shift is due to *stannic* oxide. Separation by sublimation *in vacuo* nets the dihydric phenol and pure 3,4-toluenedioxytin(II), which hydrolyzes under a nitrogen atmosphere to give the expected stannous oxide according to the equation

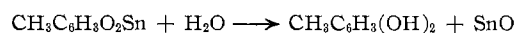

**Acknowledgment.**—Our work is supported by the Advanced Research Projects Agency. We thank Professor R. F. Porter of this department for examining our compounds in the furnace-equipped mass spectrometer.

(22) Preliminary studies on tin(IV) derivatives of these heterocyclic compounds where tin is substituted with methyl, butyl, and octyl groups show these systems fail to exhibit room-temperature resonances as well [H. S. Marsh, H. S. Sage, and J. J. Zuckerman, unpublished results].

CONTRIBUTION NO. 1814 FROM THE INSTITUTE FOR ATOMIC RESEARCH AND DEPARTMENT OF CHEMISTRY, IOWA STATE UNIVERSITY, AMES, IOWA

## An Electromotive Force Study of Lower Oxidation States of Lead, Cadmium, and Tin in Molten NaAlCl<sub>4</sub><sup>1</sup>

BY THEODORE C. F. MUNDAY AND JOHN D. CORBETT

Received November 1, 1965

Sealed cells of the type

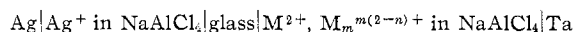

have been studied for lead, cadmium, and tin at 277°. The initial concentration of the dipositive state was ≤ 5 mole %, and the reduced ion  $\text{M}_m^{m(2-n)+}$  was produced coulometrically in conjunction with a third electrode separated by a glass frit. A one-electron reduction found for lead indicates the formation of  $\text{Pb}^+$  (or generally,  $\text{Pb}^+ \cdot n\text{Pb}^{2+}$ ). With cadmium, larger reductions were possible and the product  $\text{Cd}_2^{2+}$  could be distinguished from  $\text{Cd}^0$ ,  $\text{Cd}_3^{4+}$ , etc. A tentative result for the reduction of tin is  $\text{Sn}_2^+$  ( $\text{Sn}_3^{3+}$ , etc.). Further evidence for the enhanced stability of lower oxidation states in acidic melts is presented. Preparation of  $\text{Ni}(\text{AlCl}_4)_2$  was not possible, contrary to a recent report.

### Introduction

Studies of the apparent solution of cadmium, tin, and lead in their respective molten halides all suggest, but in some cases do not prove, that the process takes place through the formation of a lower oxidation state in the melt. For the better studied  $\text{CdCl}_2$ -Cd system, recent magnetic,<sup>2</sup> emf (oxidation-reduction),<sup>3,4</sup> Henry's law,<sup>4</sup> and cryoscopic<sup>5</sup> studies are all consistent

with the formation of a solute in the series  $\text{Cd}^0$ ,  $\text{Cd}_3^{2+}$ ,  $\text{Cd}_3^{4+}$ ,  $\text{Cd}_4^{6+}$ , etc. The uncertainty in the solute here arises from the general inability to determine the amount of  $\text{CdCl}_2$  consumed in dilute solutions of metal where ideal solution laws may be expected to apply, although the solute mobility<sup>6</sup> in this system suggests that it is charged. A similar result pertains to cadmium solution in the melt  $\text{CdCl}_2$ -KCl-NaCl,<sup>7</sup> where the metal solubility is markedly less. In opposition, a specific solute is indicated by studies in the  $\text{CdCl}_2$ -

(1) Work was performed in the Ames Laboratory of the U. S. Atomic Energy Commission.

(2) N. H. Nachtrieb, *J. Phys. Chem.*, **66**, 1163 (1962).

(3) L. E. Topol, *ibid.*, **67**, 2222 (1963).

(4) M. Okada, K. Yoshida, and Y. Hisamatsu, *J. Electrochem. Soc. Japan*, **32**, 99 (1964).

(5) L. E. Topol and A. L. Landis, *J. Am. Chem. Soc.*, **82**, 6291 (1960).

(6) W. Herzog and A. Klemm, *Z. Naturforsch.*, **15a**, 1100 (1960); C. A.

Angell and J. W. Tomlinson, *Discussions Faraday Soc.*, **32**, 237 (1961).

(7) S. Karpachev and A. Stromberg, *Zh. Fiz. Khim.*, **13**, 397 (1939).

$\text{AlCl}_3$  system, namely in  $\text{Cd}(\text{AlCl}_4)_2$ , where the metal "solubility" is sufficient to allow the separation of  $\text{Cd}_2(\text{AlCl}_4)_2$ .<sup>8</sup> A Raman study of the metal-saturated melt confirms the presence of the  $\text{Cd}_2^{2+}$  ion.<sup>9</sup>

No information has been published pertaining to the nature of the dilute (0.003 mole %) solutions which can be obtained for tin in molten  $\text{SnCl}_2$ . However, recent Henry's law<sup>10</sup> and emf<sup>3</sup> studies of lead in its halides are in agreement as to the formation of a solute in the series  $\text{Pb}^0$ ,  $\text{Pb}_2^{2+}$ ,  $\text{Pb}_3^{4+}$ , etc., in contrast to an earlier emf investigation<sup>11</sup> which suggested a one-electron reduction to  $\text{Pb}^+$  (or  $\text{Pb}_2^{3+}$ , etc.).

In the present study these three systems were studied under acidic conditions with  $\text{AlCl}_4^-$  as the anion since, as noted above, such a change from chloride has been found to increase markedly the stability of a lower oxidation state. Emf measurements were used, as these have been found to be useful with the small quantities of reduced species often encountered.<sup>3,11-13</sup> It is advantageous also to work in a common solvent, in which case solute concentrations can be conveniently varied *in situ* and over a wide range by coulometric means. The solvent system chosen was 95%  $\text{NaAlCl}_4$ -5%  $\text{AlCl}_3$ , the excess  $\text{AlCl}_3$  being added to reduce any effects of thermal dissociation of the anion.

### Experimental Section

**General.**—Potentials were measured with a K-2 potentiometer and galvanometer from Leeds and Northrup. A molten salt bath of  $\text{NaNO}_2$  and  $\text{KNO}_3$  was used to maintain constant temperature throughout the cell. Concentrations were changed coulometrically with a Model IV Sargent coulometric current source at a rate of  $0.05 \mu\text{equiv sec}^{-1}$ .

**The Cell.**—The three Pyrex compartments (Figure 1) contained, from left to right, the reference, indicator, and working anode electrodes. The junction between the reference and indicator compartments was a thin glass diaphragm and that between the indicator and working anode compartments was a 10-mm diameter ultrafine frit. Silver leads were used from a room-temperature junction point to the electrodes; these were soldered through  $\frac{1}{8}$ -in. Kovar metal-to-glass graded seals where they entered the cell. Glass tubing shielded these wires from the corrosive, conductive thermostat melt. The resistances of the glass diaphragm junctions were below 60 kohms at the experimental temperatures. A short tube which connected the indicator and working anode compartments above the level of the melt eliminated pressure gradients across the frit. The reference electrode was silver, the indicator electrode was tantalum, and the working anode was the respective metals for the lead or cadmium determinations. A carbon indicator electrode and a silver anode were used for the tin studies.

The cell was loaded through the side arms, and these were then sealed after the cell had been evacuated below discharge. Each compartment contained 4 to 6 g of  $\text{NaAlCl}_4$  and ~5 mole % of  $\text{AlCl}_3$ . The reference contained 5 mole % of  $\text{AgAlCl}_4$ . The indicator and working anode compartments contained equal percentages (usually *ca.* 5 mole %) of  $\text{Pb}(\text{AlCl}_4)_2$ ,  $\text{Cd}(\text{AlCl}_4)_2$ , or  $\text{Sn}(\text{AlCl}_4)_2$ .

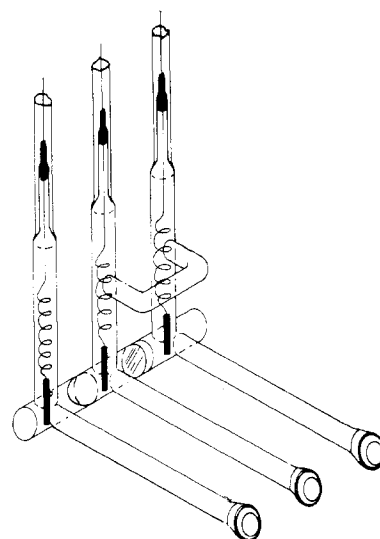

Figure 1.—The cell before being filled and sealed off. From left to right are the reference, indicator, and anode compartments.

As a general procedure the potentials of the indicator-reference and indicator-working anode couples were followed for several hours until the initial drift became negligible ( $< \sim 0.2 \text{ mv hr}^{-1}$ ). Then the concentration of the reduced ion in the indicator compartment was coulometrically increased against the working anode compartment. The potentials of both couples were recorded as soon as they became constant after each coulometric reduction. This commonly required only a few minutes after the first few reductions. However later reductions, which for equal change necessarily involved passage of larger quantities of current, generally did not reach equilibrium potentials for up to about 2 hr. The reference couple could be recovered and reused if the salt were solidified out of contact with the diaphragm.

**Materials.**—All materials were purified in glass using common vacuum line techniques, and all transfers were made in a drybox. Reagent grade  $\text{AlCl}_3$  was doubly sublimed under 100 torr of helium at  $180^\circ$ , which also effected separation of the  $\text{FeCl}_3$  impurity. The first sublimate was allowed to form a thick deposit and was then sealed under vacuum in the glass tube. The ampoule thus formed was placed in a second sublimation tube. Upon heating, the thick deposit fractured the ampoule, allowing the second sublimation to occur. In this way intermediate transfers in the drybox were avoided.

The  $\text{NaAlCl}_4$  solvent was prepared from a stoichiometric mixture of  $\text{AlCl}_3$  and reagent grade  $\text{NaCl}$  which had been dried under vacuum at  $480^\circ$ . The melt at this point was brown and could not be cleared by addition of either metallic Al or Na. Following Morrey,<sup>14</sup> the product was digested at  $450^\circ$  and filtered through a medium frit to remove a black agglomerate, evidently carbon, which formed during digestion. The  $\text{NaAlCl}_4$  produced was a white solid and gave a clear, colorless melt. The  $\text{AlCl}_3$  is thought to be a major source of the carbonaceous impurity.

Lead(II) chloride was distilled twice at  $920^\circ$  under 75 torr of chlorine, and  $\text{Pb}(\text{AlCl}_4)_2$  was then prepared by heating a stoichiometric mixture of  $\text{PbCl}_2$  and  $\text{AlCl}_3$ . Reaction produced a white solid when the  $\text{AlCl}_3$  melted at  $193^\circ$ . The tube was then pushed gradually into a furnace at  $340^\circ$  to produce a homogeneous melt, which was digested at  $450^\circ$  and filtered. Visual observation showed that the product melted congruently at  $275 \pm 2^\circ$ . Its powder pattern<sup>15</sup> showed no free  $\text{PbCl}_2$  or  $\text{AlCl}_3$  within the detection limits.

(14) J. R. Morrey, *Inorg. Chem.*, **2**, 163 (1963).

(15) Powder data obtained for  $\text{Pb}(\text{AlCl}_4)_2$ , with relative visual intensities in parentheses, are: 7.02 (10), 6.32 (1), 6.15 (4), 5.03 (0.5), 4.82 (2), 4.55 (7), 3.62 (2), 3.28 (2), 3.13 (4), 3.06 (1), 2.97 (3), 2.69 (2), 2.26 (1), 2.24 (1), 1.69 A (0.5).

(8) J. D. Corbett, W. J. Burkhard, and L. F. Druding, *J. Am. Chem. Soc.*, **83**, 76 (1961).

(9) J. D. Corbett, *Inorg. Chem.*, **1**, 700 (1962).

(10) J. J. Egan, *J. Phys. Chem.*, **65**, 2222 (1961); J. D. Van Norman, J. S. Bookless, and J. J. Egan, *ibid.*, **70**, 1276 (1966).

(11) S. Karpachev, A. Stromberg, and E. Jordan, *Zh. Fiz. Khim.*, **18**, 43 (1944).

(12) J. D. Corbett and F. C. Albers, *J. Am. Chem. Soc.*, **82**, 533 (1960).

(13) L. E. Topol, S. J. Yosim, and R. A. Osteryoung, *J. Phys. Chem.*, **65**, 1511 (1961).

Reagent grade  $\text{CdCl}_2$  was vacuum sublimed twice at  $500^\circ$ . A supplementary furnace at  $300^\circ$  was used to prevent a small amount of cadmium metal from depositing where  $\text{CdCl}_2$  would later condense. The  $\text{Cd}(\text{AlCl}_4)_2$  was prepared as before<sup>8</sup> by heating a stoichiometric mixture of  $\text{CdCl}_2$  and  $\text{AlCl}_3$ .

The  $\text{AgAlCl}_4$  was prepared by heating a stoichiometric mixture of  $\text{AlCl}_3$  and reagent grade  $\text{AgCl}$ . The product was digested at  $300^\circ$  and filtered.

The  $\text{Sn}(\text{AlCl}_4)_2$  was prepared from the stoichiometric mixture of sublimed components, digested at  $390^\circ$ , and filtered. The material melted congruently at  $223 \pm 2^\circ$  and contained neither of the original components according to X-ray powder patterns.

It proved impossible to make  $\text{Ni}(\text{AlCl}_4)_2$  or even to obtain a suitable concentration of  $\text{Ni}^{2+}$  in  $\text{NaAlCl}_4$ . Vacuum-sublimed  $\text{NiCl}_2$  did not react with solid  $\text{AlCl}_3$  at  $160^\circ$  or dissolve in the liquid to an appreciable extent in 3 weeks at  $225$  or  $240^\circ$ . Also,  $\text{NiCl}_2$  at  $500^\circ$  did not react with  $\text{AlCl}_3(\text{g})$  from a reservoir at  $240^\circ$ , and 1:2 mixtures heated with various amounts of  $\text{NaAlCl}_4$  as a flux gave only recrystallized  $\text{NiCl}_2$ . The solubility of  $\text{NiCl}_2$  in liquid  $\text{NaAlCl}_4$  containing 7%  $\text{AlCl}_3$  is estimated to be less than 0.1 mole % at  $300^\circ$ . It is noteworthy that Øye and Gruen<sup>16</sup> have obtained closer to 1%  $\text{NiCl}_2$  in  $\text{AlCl}_3$  at  $227^\circ$  with  $\text{NiCl}_2$  which had been dehydrated under  $\text{HCl}(\text{g})$  but not sublimed.

## Results

**Treatment of Data.**—The apparatus employed actually contains two observable cells with a common electrode. The principal cell is  $\text{Ag}|\text{Ag}^+|\text{glass}|\text{M}^{2+}, \text{M}_m^{m(2-n)+}|\text{Ta}$ , where the Ta indicator electrode is sensitive to the oxidation–reduction couple of interest, and the glass membrane passes  $\text{Na}^+$  ions but prevents mixing. A second cell, comprised of the indicator and the working anode, is  $\text{Ta}|\text{M}^{2+}, \text{M}_m^{m(2-n)+}|\text{frit}|\text{M}^{2+}, \text{M}_m^{m(2-n)+}(\text{satd})|\text{M}$ . This circuit enables coulometric reduction of  $\text{M}^{2+}$ , but it also functions as a concentration cell with a metal-saturated reference, although it was not considered to be a primary source of data. It should be noted that the same  $\text{NaAlCl}_4\text{--AlCl}_3$  (95:5) solvent was used throughout.

With a reducible, divalent ion  $\text{M}^{2+}$  present in the indicator compartment, coulometric reduction will produce an undesigned, reduced ion according to the reaction

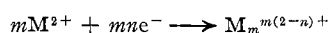

where  $n$  represents the (average) number of electrons involved in reduction of each  $\text{M}^{2+}$  ion, and  $m$  is the degree of catenation of the reduced species. Therefore, if the original concentration of  $\text{M}^{2+}$  is  $C_0$  equivalents, the concentration will be  $[C_0 - q_i/n]$  after  $q_i$  equivalents of reduction. Similarly, if the original concentration of reduced species is zero, its concentration after  $q_i$  equivalents of reduction will be  $q_i/mn$ .

Substitution of these quantities into the Nernst equation gives

$$E = 2.3RT/mnF \log [(C_0 - q_i/n)^m/q_i] + \text{constant} \quad (1)$$

This expression assumes that  $m$ ,  $n$ , any junction potential,<sup>17</sup> and the voltage of the reference couple are

(16) H. A. Øye and D. M. Gruen, *Inorg. Chem.*, **3**, 836 (1964).

(17) Since essentially the same  $\text{NaAlCl}_4$  concentration was present on both sides of the glass junction, the junction potential was probably negligible, although it need only be constant. For further discussion see R. W. Laity in "Reference Electrodes," D. J. G. Ives and G. J. Janz, Eds., Academic Press Inc., New York, N. Y., 1961, pp. 524–606, and K. Notz and A. G. Keenan, *J. Phys. Chem.*, **70**, 662 (1966).

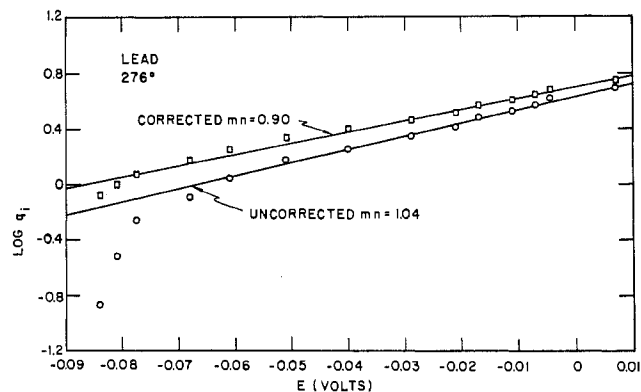

Figure 2.—Data for lead, run 1, according to eq 2.

constant. It also presumes the activity coefficients of the oxidized and reduced species remain constant in the range studied, a reasonable assumption for the dilute solutions employed.<sup>18</sup> In the case where  $q_i$  is small compared with  $C_0$ , the  $\text{M}^{2+}$  concentration is effectively constant, and the expression reduces to

$$E = 2.3RT/mnF \log q_i + \text{constant}' \quad (2)$$

A graph of  $\log q_i$  vs.  $E$  then yields a slope of  $(2.3RT/mnF)^{-1}$ , from which the  $mn$  product may be determined. Separation of  $m$  and  $n$  requires data in which  $q_i$  is not small compared to  $C_0$ , as will be considered shortly for cadmium.

**Impurities.**—In every case the first few points of the  $\log q_i$  vs.  $E$  plot showed a negative deviation from the linear portion, as shown in Figure 2 for one of the lead studies. Similar behavior has been observed previously<sup>3,13</sup> and attributed to the initial presence of some of the reduced species. In one case<sup>13</sup> an oxidizable entity was detected polarographically. In the present study the initial voltage observed slowly drifted in a positive direction, the same direction as that caused by later coulometric production of the reduced species, before becoming steady. Equilibration of the melts in the side arms during this initial period did not significantly affect the amount of the drift, so diffusion through the frit and interactions with the electrode materials could not have been responsible. Thus, it is likely that a reduced species was being produced during the initial decay by reactions involving minor impurities, possibly those associated with the production of carbon on prior digestion (see Experimental Section).

The assumption that this initial product is the same as that produced later coulometrically is supported by the general linearity of plots obtained for the data after correction for the initial impurity, as follows. The initial amount of the suspected reduced species at equilibrium,  $q_0$ , was calculated from the  $E - q_i$  data for the first and last points by eq 2, substituting  $(q_i + q_0)$  for  $q_i$  and using the integral  $mn$  product ob-

(18) The maximum reduced solute concentration encountered was 0.38 mole %, and the usual value was much lower, so that Henry's law was probably obeyed.  $\text{M}^{2+}$  concentrations were either less than 0.2% or sufficiently large (4 to 5%) to remain substantially constant for a relatively small amount of reduction.

tained from the  $\log q_i$  vs.  $E$  plot. Corrected plots were then used to evaluate final  $mn$  values, which are necessarily less than those obtained from uncorrected data.

The potentials of the cells generally exhibited remarkable stability. While only about 3 hr was necessary to obtain data essentially defining  $mn$ , subsequent data measured over an additional 24 hr were consistent with the earlier points.

Data were evaluated for both the indicator-reference and the indicator-working anode couples assuming that the working anode remained continuously saturated with the lower oxidation state species and thus served as a satisfactory, secondary reference couple. The results are given in Table I together with the calculated  $q_0$  values. Cells were measured at constant temperatures between 275 and 279°.

TABLE I  
EMF RESULTS FOR THE REDUCTION OF  $Pb^{2+}$ ,  $Cd^{2+}$ , AND  $Sn^{2+}$  IN  $NaAlCl_4$  SOLVENT

	$mn$		$C_0$ , mole %	Final % re- duction <sup>a</sup>	Calcd $q_0$ , mole %
	Uncor	Cor			
Lead					
Indicator-reference					
Run 1	1.04	0.90	5.0	0.4	0.002
Run 2	1.26	1.00	5.0	1.1	0.009
Indicator-working anode					
Run 1	1.24	1.04	5.0	0.4	0.002
Run 2	1.42	1.08	5.0	1.1	0.02
Cadmium					
Indicator-reference					
Run 1	2.56	1.98	3.8	4.6	0.03
Run 1 <sup>b</sup>	2.73	2.03	3.8	4.6	0.03
Run 2 <sup>b</sup>	2.78	2.02	0.2	34	0.02
Run 3 <sup>b</sup>	1.93	1.84	0.1	37	0.0003
Indicator-working anode					
Run 1 <sup>b</sup>	1.50	1.44	3.8	4.6	0.01
Run 2 <sup>b</sup>	2.52	2.00	0.2	34	0.02
Tin					
Indicator-reference	3.55	2.92	5.4	0.45	0.004

<sup>a</sup> To simplest ionic solute. <sup>b</sup> Result from  $\log [(C_0 - q_i)^2/q_i]$  vs.  $E$ , eq 1.

**Lead.**—The catenation  $m$  of the reduced species produced from a single  $M^{2+}$  cation is reasonably limited to small integral values, while  $n$  may assume any real value in the interval (0, 2). Furthermore, the  $mn$  product must be integral. It is clear from Figure 2 (and Table I) that  $mn$  equals 1 for lead; in fact, the impurity correction is not important here as  $q_i$  rapidly becomes large compared to  $q_0$ . This result corresponds to  $Pb^+$ ,  $Pb_2^{3+}$ ,  $Pb_3^{5+}$ , etc., as the reduced product. The ambiguity arises from the inseparability of  $m$  and  $n$  under these conditions or, in other words, the inability to determine the number of  $Pb^{2+}$  ions involved in the formation of each product ion in dilute solution.

**Cadmium.**—Data for run 1 (Table I) indicate that the  $mn$  product is 2 with a 3.8% solution of  $Cd(AlCl_4)_2$  and a relatively small reduction. Correction for the

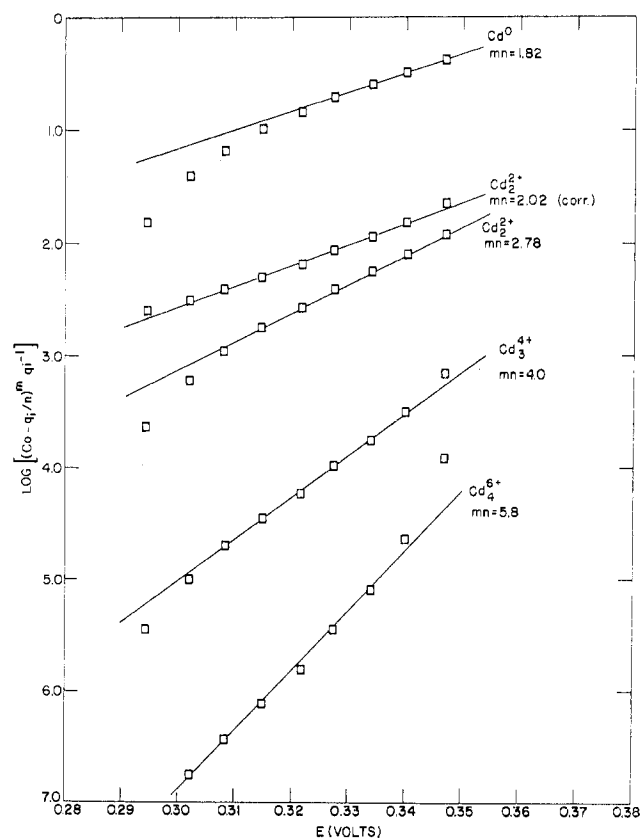

Figure 3.—Data for cadmium, run 2, plotted by eq 1 for various, presumed species for which  $mn = 2$ , and the resultant  $mn$  products.

apparent initial concentration of reduced species necessitated assumption of an  $mn$  value and the use of 2 for this produced the same integral, corrected  $mn$  value, as required. If  $mn = 3$  is assumed, the deviated points are not corrected, and an integral  $mn$  value does not result ( $\sim 2.4$  at the midpoint). A value of 2 for  $mn$  for cadmium is consistent with  $Cd^0$ ,  $Cd_2^{2+}$ ,  $Cd_3^{4+}$ , etc., as the possible reduced forms, a not unexpected result.

Two cadmium cells, runs 2 and 3 (Table I), were operated so that  $q_i$  was not negligible compared with  $C_0$ . Such data can be treated by eq 1 by assuming that the  $mn = 2$  result of run 1 is correct and choosing  $m$  and  $n$  values within the limits imposed. This in effect allows the amount of  $Cd^{2+}$  ( $m$ ) necessary to form each reduced ion to be deduced under conditions where this has a significant effect on  $C_0$ , presuming that the correct choice will reproduce the above  $mn = 2$  result.

Figure 3 illustrates the results of such treatment of the data of run 2. The second and third curves show the very consistent result that is obtained for  $Cd_2^{2+}$  ( $m = 2, n = 1$ ), the two plots being for the result of a  $q_0$  correction applied as before and uncorrected, respectively. On the other hand, reduced species  $Cd_3^{4+}$  ( $m = 3, n = 2/3$ ),  $Cd_4^{6+}$  ( $m = 4, n = 1/2$ ), as well as more complex choices are readily eliminated since the plots (Figure 3, bottom) produce slopes which are not consistent with the  $mn$  product of 2. For these species the initial impurity deviations otherwise always ob-

TABLE II  
 METAL SOLUBILITIES IN DIFFERENT SOLVENTS (MOLE % METAL)

M	MCl <sub>2</sub>	t, °C	M(AlCl <sub>4</sub> ) <sub>2</sub>	Solvent			
				t, °C	5 mole % M(AlCl <sub>4</sub> ) <sub>2</sub> + 90 mole % NaAlCl <sub>4</sub> + 5 mole % AlCl <sub>3</sub> Total melt	M/(M <sup>2+</sup> + M)	t, °C
Cd	15	540 <sup>a</sup>	40	335 <sup>b</sup>	3.8 ± 0.3	43	±00
Pb	0.006	500 <sup>c</sup>	0.2 ± 0.03	305	0.16 ± 0.03	2.4 ± 0.1	300
Sn	0.003	500 <sup>c</sup>	0.1 ± 0.03	290	0.06 ± 0.03	1.1 ± 0.1	305

<sup>a</sup> See ref 5. <sup>b</sup> See ref 8. <sup>c</sup> J. D. Corbett and S. von Winbush, *J. Am. Chem. Soc.*, **77**, 3964 (1955).

served are largely or entirely missing. If the Cd<sub>3</sub><sup>4+</sup> plot is corrected with the same  $q_0$  as used for Cd<sub>2</sub><sup>2+</sup>,  $mn$  is reduced to only 3.1, and the function is nonlinear (overcorrected). Although treatment of the data in terms of Cd<sup>0</sup> ( $m = 1$ ,  $n = 2$ ) (top curve) reproduces a plausible  $mn$  product of 1.82 in the higher concentration range, the first half of the points deviates badly. As expected, a suitable  $q_0$  correction decreases the slope and gives an unsatisfactory product of 1.37. A similar treatment for lead or tin is not possible because of the much lower concentration of the reduced species at saturation.

With regard to other cadmium data in Table I, the indicator-reference data for run 3 (a preliminary experiment with an aluminum working anode) exhibited about twice as much scatter as the others, so  $mn$  is probably uncertain by  $\pm 0.1$ . The indicator-working anode cell for run 1 gave poor data, with an average deviation six times that found with the other cell or throughout run 2. The apparently more satisfactory concentration cell in run 2 extrapolated to a  $q_1$  value at zero voltage (saturation) of 40 mole % metal, in good agreement with a direct determination reported below.

**Tin.**—Three initial experiments with molten tin anodes gave generally inconsistent results suggestive of diffusion through the frit. The cell was therefore modified so that the frit was offset from the line joining the indicator electrode and the silver anode. In a tipped position the melts were thus in contact with the electrodes but not the frit so that equilibrium reference-indicator potentials could be measured without diffusion. The cell was moved so that the melt contacted the frit only during the relatively short periods necessary for coulometric reductions. The electrodes were immersed to about the same depth in either position.

The more nearly linear plot which resulted from this experiment is shown in Figure 4. In this case the impurity reduction was calculated from the second point as the first is inconsistent and evidently in error. The tentative  $mn = 3$  result corresponds to a product Sn<sub>2</sub><sup>+</sup>, Sn<sub>3</sub><sup>3+</sup>, Sn<sub>4</sub><sup>5+</sup>, etc. The earlier and irregular  $mn$  values which were rejected ranged from 4.5 to 9, indicating previous cells were probably troubled by higher initial impurities, at the saturation level in one case, rather than by diffusion.

**Limiting Reduction.**—The solubilities of lead and tin in the respective tetrachloroaluminates as well as of these and cadmium in the solution 5% M(AlCl<sub>4</sub>)<sub>2</sub>-90% NaAlCl<sub>4</sub>-5% AlCl<sub>3</sub> were determined from the weight loss of metal buttons equilibrated with known

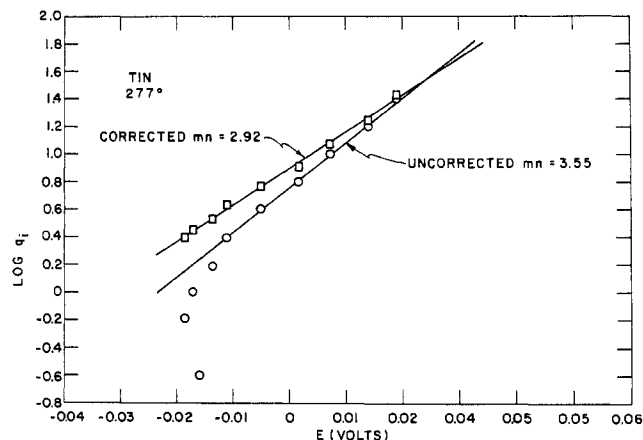

Figure 4.—Data for tin according to eq 2.

amounts of melt. The results together with literature data for the chlorides are summarized in Table II. The second column for the NaAlCl<sub>4</sub>-AlCl<sub>3</sub> solvent gives a comparative value based on only the moles of M(AlCl<sub>4</sub>)<sub>2</sub> therein.

### Discussion

The results for lead indicate Pb<sup>+</sup> (or Pb<sub>2</sub><sup>3+</sup>, etc.) is found on reduction of Pb<sup>2+</sup> in tetrachloroaluminate solvent. This is in contrast to the product Pb<sup>0</sup>, Pb<sub>2</sub><sup>2+</sup>, etc., indicated by three concordant studies<sup>3,10</sup> in pure PbCl<sub>2</sub>. The reduction of lead must thus be presumed to be dependent on the nature of the solvent. On the other hand, the cadmium product Cd<sub>2</sub><sup>2+</sup> found in NaAlCl<sub>4</sub> is consistent with all other studies (*cf.* Introduction) in the pure molten chloride as well as in pure Cd(AlCl<sub>4</sub>)<sub>2</sub>, where such a cadmium(I) state may also be obtained as a solid product after more extensive reduction. However, the present study is the first time that a sufficient reduction has been carried out in dilute solution where ideal behavior would be expected so that the Cd<sub>2</sub><sup>2+</sup> product may be distinguished from metal atoms as well as from the higher allowed species Cd<sub>3</sub><sup>4+</sup>, Cd<sub>4</sub><sup>6+</sup>, etc. An earlier interpretation of cryoscopic data<sup>5</sup> in favor of the tri- or tetraatomic cations in molten CdCl<sub>2</sub> was based on the properties of solutions containing 5 to 10 mole % metal, where ideal behavior of the solvent may no longer pertain. The tentative result of the reduction of Sn<sup>2+</sup> in NaAlCl<sub>4</sub>, Sn<sub>2</sub><sup>+</sup>, etc., is without precedent and no other quantitative studies of the reduction of this species have been published. Both the lead and tin products should be observable by sensitive magnetic techniques.

The effect of the anion on the reduction limits of these elements given in Table II further supports the

"acid stabilization" concept previously applied to the cadmium(I)<sup>10</sup> and gallium(I)<sup>19</sup> systems. The metal solubility in, or extent of reduction of, lead(II) and tin(II) salts increases about 30-fold when the anion is changed from chloride to tetrachloroaluminate, although this is still insufficient for stabilization of a solid product.

Dilution with solvent NaAlCl<sub>4</sub>-AlCl<sub>3</sub>, of course, reduces the total amount of metal solution per mole of solution. However, the mole fraction solubility based only on M<sup>2+</sup> content [M/(M<sup>II</sup> + M)] shows an interesting correlation with the proposed solute species on dilution from M(AlCl<sub>4</sub>)<sub>2</sub> to the 5% solution. For a Cd<sup>2+</sup> product the equilibrium position ideally should not be dependent on dilution, as observed, whereas reduction of the dipositive cations to Pb<sup>+</sup> or Sn<sub>2</sub><sup>+</sup> (but *not* to the higher species) should increase on dilution, as observed. The actual change is about twice that expected for this simple treatment, suggesting a specific solvent effect. However, a quantitative argument regarding dilution effects is dangerous here, since it presumes proportional activity changes on dilution, such as Raoultian for Sn<sup>2+</sup> or Pb<sup>2+</sup> from 100 to 5% M(AlCl<sub>4</sub>)<sub>2</sub> and the same Henry's law constant for the reduced ion throughout the dilution. Although this may not be an atrocious assumption, it is by no means assured.

An emf study of reduction of Ni<sup>2+</sup> would be interesting in view of the substantial (9%) solution of the metal in molten NiCl<sub>2</sub>.<sup>20</sup> However, investigations of this in the tetrachloroaluminate solvent were frustrated

by the inability to obtain reasonable concentrations of NiCl<sub>2</sub> in NaAlCl<sub>4</sub>, let alone to form solid Ni(AlCl<sub>4</sub>)<sub>2</sub> (see Experimental Section). This is somewhat surprising in view of the known stability of Co(AlCl<sub>4</sub>)<sub>2</sub>,<sup>21</sup> but may be a result of the higher lattice energy of NiCl<sub>2</sub>.

Synthetic work preliminary to the emf studies indicated the formation of MCl<sub>2</sub>-2AlCl<sub>3</sub> compounds for tin and lead, the evidence being the totally unique powder patterns and the congruent melting points at this composition (see Experimental Section). For convenience these have been regarded herein as tetrachloroaluminates, an entirely reasonable but not established formulation. Recently, Belt and Scott<sup>22</sup> have reported X-ray powder data for some of the same systems but with somewhat different results. Our data for Sn(AlCl<sub>4</sub>)<sub>2</sub> are in good agreement with theirs except that they appear to have included about five of the principal diffractions of AlCl<sub>3</sub>. (The same spacings are also found in the data reported for a number of other systems.) However, their data for the PbCl<sub>2</sub>-2AlCl<sub>3</sub> composition are in very poor agreement with those<sup>15</sup> obtained here. They also gave data reported to support the formation of a NiCl<sub>2</sub>-AlCl<sub>3</sub> compound, contrary to our experience. Their data do not appear very conclusive, however, since at least 90% of the diffraction spacings given can be assigned to those of the original components. The reported green color is also at variance with either the yellow color of NiCl<sub>2</sub> observed for all solid systems or the rose to salmon colors of the very dilute melts. The use of "anhydrous" or dehydrated commercial reagents without further purification may have caused some difficulties in the earlier work.

(19) R. K. McMullan and J. D. Corbett, *J. Am. Chem. Soc.*, **80**, 4761 (1958).

(20) J. W. Johnson, D. Cubicciotti, and C. M. Kelley, *J. Phys. Chem.*, **62**, 1107 (1958).

(21) J. A. Ibers, *Acta Cryst.*, **15**, 967 (1962).

(22) R. F. Belt and H. Scott, *Inorg. Chem.*, **3**, 1785 (1964).

CONTRIBUTION FROM THE DEPARTMENT OF GEOLOGY AND GEOPHYSICS, UNIVERSITY OF CALIFORNIA, BERKELEY, CALIFORNIA, AND THE DEPARTMENT OF THEORETICAL CHEMISTRY, UNIVERSITY OF CAMBRIDGE, CAMBRIDGE, ENGLAND

## Vibronic Polarization in the Electronic Spectra of Gillespite, a Mineral Containing Iron(II) in Square-Planar Coordination

BY ROGER G. BURNS,<sup>1</sup> MICHAEL G. CLARK,<sup>2</sup> AND ANTHONY J. STONE<sup>2</sup>

Received February 11, 1966

The polarized absorption spectra of iron in the mineral gillespite (BaFeSi<sub>4</sub>O<sub>10</sub>) have been measured in the region 4000-15,000 Å. It has been shown that the spectra may be interpreted satisfactorily if it is supposed that the order of increasing energy of the 3d orbitals of the iron is  $d_{z^2} < d_{xz}, d_{yz} < d_{xy} < d_{x^2-y^2}$ . Approximate values for the energy separations of these orbitals in the high-spin configuration of the iron have been deduced. Vibronic polarization in the spectra of gillespite has been treated by the methods of group theory.

### Introduction

Square-planar coordination by oxygen of ferrous iron is rare.<sup>3</sup> It is therefore of interest to examine the

mineral gillespite, which is an example of this coordination.<sup>4</sup> The polarized absorption spectra in the region

(1) University of California; address correspondence to the Department of Mineralogy and Petrology, University of Cambridge, Cambridge, England.

(2) University of Cambridge.

(3) (a) N. V. Sidgwick, "Chemical Elements and Their Compounds," Vol. 2, Oxford University Press, London, 1950, p 1347; (b) F. A. Cotton and G. Wilkinson, "Advanced Inorganic Chemistry," Interscience Publishers, Inc., New York, N. Y., 1962, p 711; (c) D. P. Mellor, *Chem. Rev.*, **33**, 179 (1943).

(4) A. Pabst, *Am. Mineralogist*, **28**, 372 (1943).